



SwiftWing HVPM-01A

High Voltage Analog Power Module for ArduPilot & PX4

Official Technical Datasheet | Document ID: SW-HVPM-01A-v1.2 | Release Date: Jun 2026
SKU: SW-HVPM-01A

Product Page: <https://swiftwingtech.io/product/swiftwing-high-voltage-analog-power-module-01a/>

Product Overview

The SwiftWing HVPM-01A is a high-voltage analog power module designed for Pixhawk, CubePilot, ArduPilot and PX4 based UAV platforms operating from 2S to 14S battery systems.

The module provides stable 5.3V regulated power for flight controllers while simultaneously delivering accurate battery voltage and current monitoring through standard analog power-module interfaces.

Designed for multirotor, VTOL and fixed-wing UAV applications operating from 9V to 60V, the HVPM-01A integrates a low-resistance current path, precision shunt-based current sensing, transient protection circuitry, and a Rubycon low-ESR input capacitor for improved power stability under dynamic flight loads.

Its compact inline XT60 form factor enables simple integration into multirotor, VTOL, fixed-wing and robotics platforms.

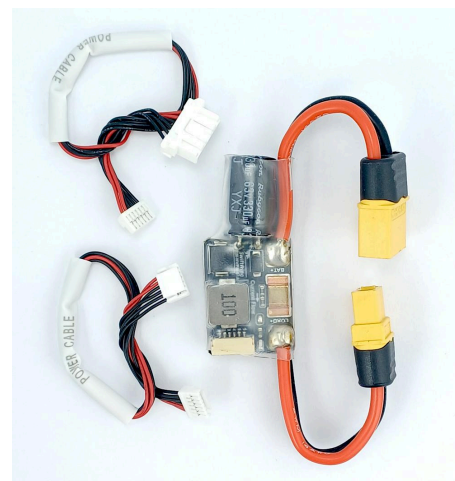

Figure 1: SwiftWing HVPM-01A

Key Features

- Supports 2S–14S LiPo battery systems (9V–60V)
- Provides regulated 5.3V power for Pixhawk and Cube flight controllers
- 3A continuous / 5A peak BEC output
- Battery voltage monitoring up to 60V
- Current monitoring up to 120A
- Precision shunt-based current sensing
- Integrated Rubycon 330 μ F 63V low-ESR input capacitor
- Transient voltage suppression (TVS) protection
- Compact inline XT60 form factor
- JST-GH 6-pin flight controller interface
- Compatible with ArduPilot and PX4 ecosystems
- Lightweight design at only 29g including connectors

Main Functions

The HVPM-01A performs three primary functions within a UAV power system:

1. Supplies regulated 5.3V power to the flight controller.
2. Measures battery voltage and reports it through the analog power-module interface.
3. Measures system current consumption through a precision shunt resistor and reports it through the analog power-module interface.

This allows ArduPilot and PX4 based systems to monitor battery voltage, current draw, consumed capacity and remaining battery status during flight.

Typical Applications

- ArduPilot-based UAVs
- PX4 flight controllers
- Industrial drones
- Long-endurance UAVs
- VTOL aircraft
- Robotics systems
- Custom autopilot platforms

Product Views

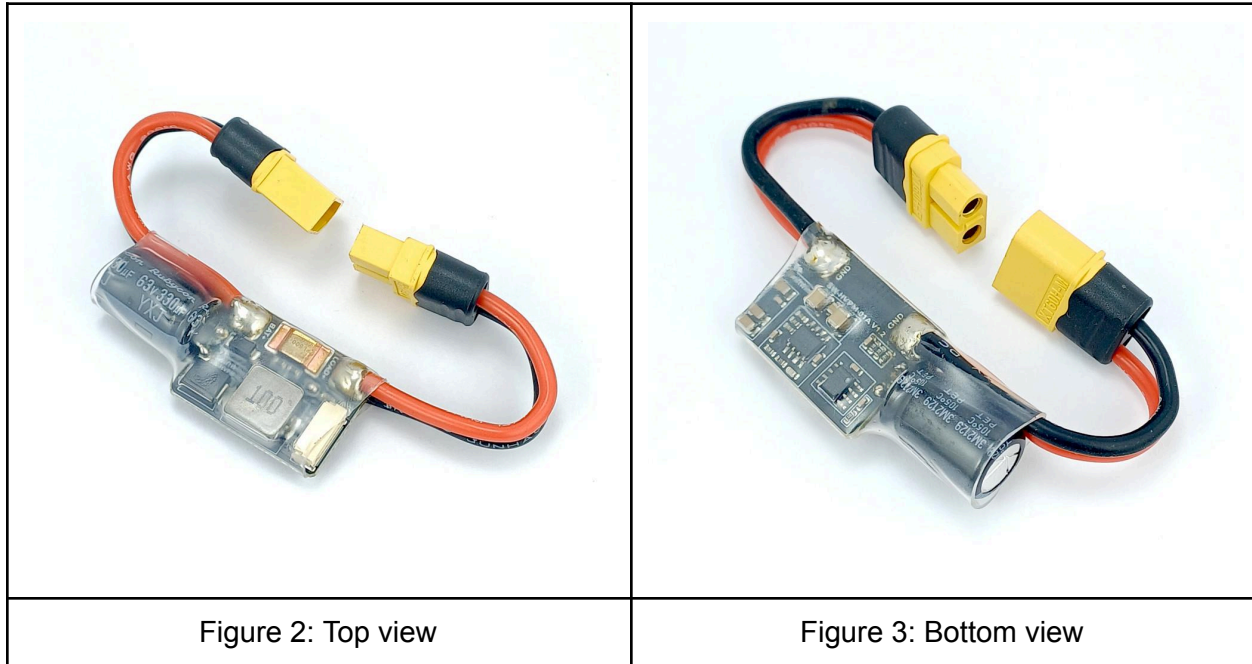

Figure 2: Top view

Figure 3: Bottom view

Absolute Maximum Ratings

The following ratings define the maximum limits beyond which permanent damage to the device may occur. Operation beyond these conditions is not recommended.

Parameter	Rating
Maximum Input Voltage	60V DC
Maximum Burst Current	120 A
5 V Output Current (Peak, <3 s)	5A
Maximum PCB Temperature	105°C

Note: Operation beyond these limits may result in permanent damage.

Electrical Specifications

Electrical characteristics measured under nominal operating conditions unless otherwise specified.

Parameter	Specification
Recommended Operating Voltage	9V-60V
Design Operating Range	2S–14S LiPo
Recommended Continuous Current	60A (XT60-equipped assembly)
Maximum Measurement Range	120 A
BEC Output Voltage	5.3V \pm 3%
BEC Output Current	3A Continuous
BEC Output Current (peak)	5A
BEC Efficiency	Up to 90% typical
Voltage Measurement Range	0–60V
Current Measurement Range	0–120A
Current Sensor Type	Precision shunt-based
Voltage Sensor Type	Resistive divider
Voltage Divider	20.66
Amperes per Volt	40
Flight Controller Interface	JST-GH 6-pin
Protection	Transient Protection (TVS)
PCB Construction	4-Layer, 2 oz Copper
Operating Temperature	–10°C to +60°C
Storage Temperature	–20°C to +85°C

 External fusing and correct battery polarity are recommended.

Note:

- Maximum current depends on external battery connector, wiring gauge, solder quality, and thermal conditions.
- BEC Output voltages are intentionally regulated slightly above nominal (5V) to compensate for wiring and connector voltage drops under load.

- Current capability of the HVPM-01A is primarily determined by the installed connector system, wiring gauge, solder quality, cooling conditions and operating environment. The internal PCB current path is designed with 4-layer construction and 2 oz copper to support high-current UAV applications with minimal voltage drop.

Accuracy

Parameter	Typical Accuracy
Voltage Measurement	±2% Typical Accuracy (after calibration)
Current Measurement	±2% Typical Accuracy (after calibration)

Input Filtering Capacitor

Parameter	Rating
Capacitor Type	Conductive Polymer Aluminum Electrolytic
Manufacturer	Rubycon
Capacitance	330uF
Voltage Rating	63 V
ESR	Low ESR
Purpose	Input ripple suppression and transient filtering

Description

The HVPM-01A incorporates a Rubycon low-ESR 330 μF / 63 V capacitor located directly across the battery input. The capacitor improves voltage stability during rapid load changes, reduces input ripple, and suppresses transient voltage spikes generated by ESC switching activity and long battery leads.

Benefits

- Improved power stability
- Reduced voltage spikes
- Enhanced flight controller reliability
- Improved buck regulator performance
- Reduced conducted noise

Mechanical Specifications

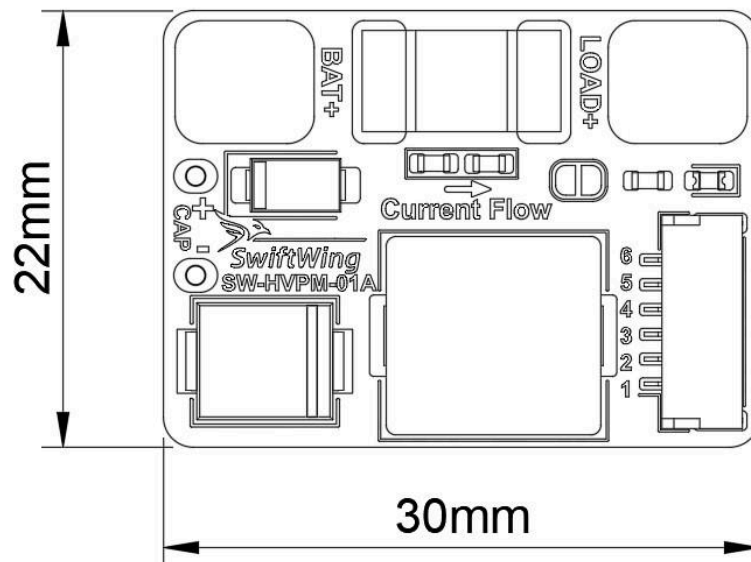

Fig: PCB Dimensions

Parameter	Value
-----------	-------

PCB Size (L x W)	30 mm × 22 mm
Assembled Product Length (including capacitor)	50 mm
Wiring length	70 mm on each side.
Maximum Height	10.3 mm
PCB Thickness	1.6 mm ±0.15 mm
Weight	29 g (fully assembled with capacitor, wiring and XT60 connectors)
PCB Layers	4-Layer, 2 oz Copper
Enclosure	Transparent Heat Shrink

Connector Pinout

JST-GH 6-Pin Pinout

Pin	Signal
1	5V
2	5V
3	Current Sense
4	Voltage Sense
5	GND
6	GND

Typical System wiring diagram

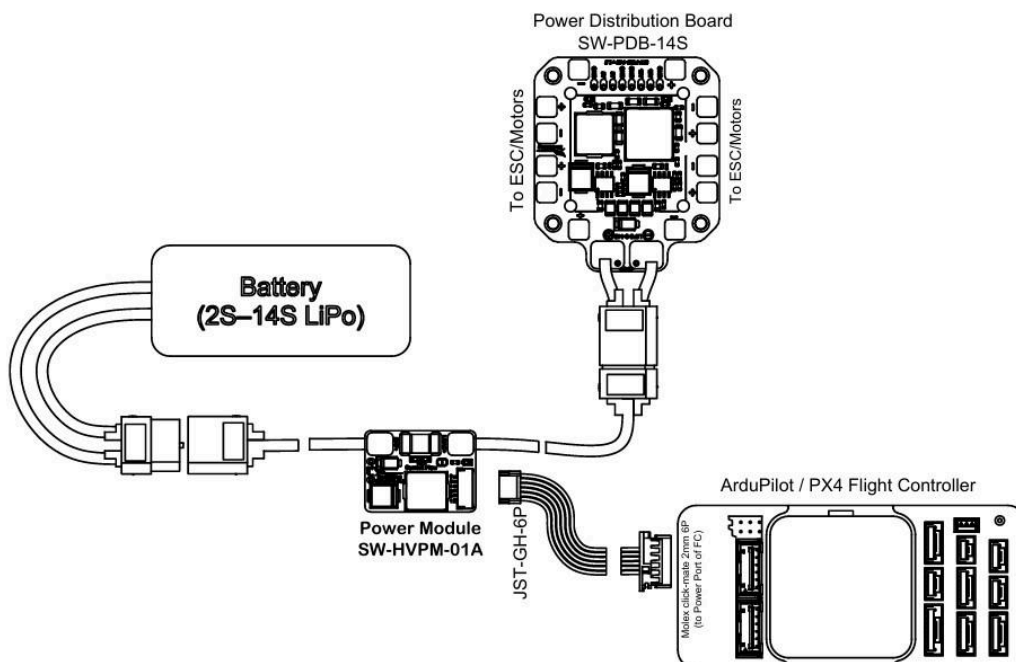

The HVPM-01A should be installed in series between the battery and the primary power distribution path to enable accurate voltage and current measurement.

ArduPilot & PX4 Configuration

ArduPilot Mission Planner Setup

1. Connect the Power Module to the battery and connect the flight controller to your ground station via USB.
2. Open Mission Planner, go to the *Setup* page and *Battery Monitor* tab, and set the parameters as per below table:

Note:

After configuring the Battery Monitor type, click "Write Params" and reboot the flight controller. Depending on the firmware version, the voltage-divider (BATT_VOLT_MULT) and current-scaling (BATT_AMP_PERVLT) parameters may only appear after the flight controller restarts.

Parameter	Value
BATT_MONITOR	Analog Voltage and Current
Sensor	Other
HW Ver	Set this as per the flight controller being used.
BATT_VOLT_MULT	20.66
BATT_AMP_PERVLT	40

Mission Planner 1.3.83 build 1.3.9384.38258 ArduCopter V4.6.3 (92b0cd78) on CubeOrangePlus 00330028 30325114 33383839

DATA PLAN SETUP CONFIG SIMULATION HELP

Install Firmware

>> **Mandatory Hardware**

>> **Optional Hardware**

RTK/GPS Inject

CubeID Update

Sik Radio

CAN GPS Order

Battery Monitor

Battery Monitor 2

DroneCAN/UAVCAN

Joystick

Monitor: Analog Voltage and Current

Sensor: 0: Other

HW Ver: 8: Cube Orange

Battery Capacity: 16000 mAh

MP Alert on Low Battery

Calibration

1. Measured battery voltage: 8.87302828123

2. Battery voltage (Calced): 8.87302828123

3. Voltage divider (Calced): 20.66

4. Measured current:

5. Current (Calced): 4.44000005722

6. Amperes per volt: 40

PX4 QGroundControl Setup

Refer to the PX4 [official documentation page](#).

1. Connect the Power Module to a battery and connect the flight controller to your ground station via USB.
2. Open QGroundControl go *Vehicle Setup* and *Power* tab and Input the Number of Cells.
3. Set the Voltage Divider & Amps per Volt as per below table.

Parameter	Value
Battery Source	Power Module
Voltage Divider	20.66
Amps per Volt	40

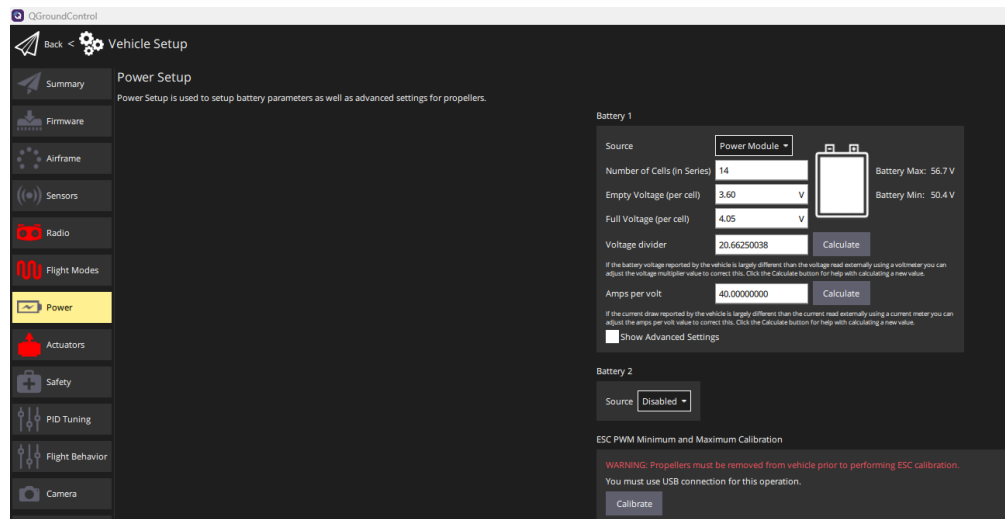

Calibration Note

The supplied voltage-divider and current-scaling values are nominal design values and provide a suitable starting point for most installations.

Due to normal component tolerances, manufacturing variations, flight-controller ADC tolerances and wiring differences, the measured battery voltage and current may differ slightly from actual values.

For best accuracy, SwiftWing recommends performing a final calibration after installation:

1. Connect a battery to the power module.
2. Measure the battery voltage using a calibrated multimeter.
3. Compare the measured voltage with the value reported by the flight controller.
4. Adjust the Voltage Divider parameter until the reported voltage matches the measured voltage.
5. Apply a known load and compare the reported current against a calibrated current meter.
6. Adjust the Current Scaling (Amps per Volt) parameter until the reported current matches the measured value.

Performing this calibration typically results in the most accurate battery-voltage, current-consumption and remaining-capacity estimates.

Supported Flight Controllers

The SwiftWing HVPM-01A utilizes the industry-standard analog power module interface and is designed for compatibility with flight controllers supporting analog voltage and current monitoring through a dedicated power-module port.

Compatible flight controllers typically include:

- CubePilot Cube series (Cube Orange, Cube Orange+, Cube Red, etc.)
- Pixhawk 4 series
- Pixhawk 6 series
- Holybro flight controllers with analog power-module support
- CUAV flight controllers with analog power-module support
- Other ArduPilot and PX4 compatible flight controllers supporting analog voltage and current sensing

Flight controller configuration parameters may vary depending on firmware version and platform. Refer to the corresponding flight-controller documentation for setup and calibration procedures.

Compliance

- RoHS-compliant PCB materials and components
- Designed for UAV and robotics applications
- Intended for integration by qualified personnel

Formal third-party certification is not included unless explicitly stated.

Connector & Assembly Notes

- Observe correct battery polarity
- Verify flight controller power-module settings
- Use supplied JST-GH cable
- Do not exceed 60V input
- Ensure adequate cooling

- Inspect solder joints before operation

What's in the Box

- 1 × SwiftWing HVPM-01A Power Module with XT60 Male and XT60 Female pre-installed & electrolytic capacitor, 330uF 63V (pre-soldered)
- 1 × JST-GH 6-pin cable to JST-GH 6-pin cable (15 cm)
- 1 x JST-GH 6-pin cable to Molex Click-mate 2 mm 6P cable. (15 cm)

Ordering Information

Product Name	SKU
SwiftWing High Voltage Analog Power Module	SW-HVPM-01A

Manufacturer Information

Manufacturer: SwiftWing Robotics
Product Category: Power Modules
Model: SwiftWing High Voltage Analog Power Module
SKU: SW-HVPM-01A

Product Page:

<https://swiftwingtech.io/product/swiftwing-high-voltage-analog-power-module-01a/>

Website:

<https://swiftwingtech.io>

Disclaimer

Specifications provided in this datasheet are subject to change without notice. While every effort has been made to ensure accuracy, SwiftWing Robotics makes no representations or warranties regarding the completeness or suitability of this information for any particular application.

This product is intended for integration into UAV and multirotor systems by qualified personnel. Incorrect installation, improper battery polarity, insufficient cooling, or operation beyond specified ratings may result in equipment damage or personal injury.

SwiftWing Robotics shall not be held liable for any direct, indirect, incidental, or consequential damages arising from the use or misuse of this product.

Users are responsible for verifying product suitability and ensuring safe system integration.

Revision History

Version	Date	Description
v1.0	May, 2026	Initial Release
v1.2	Jun 2026	Updated electrical specifications, added high-voltage guidelines, capacitor recommendations, and documentation refinements